

RevNo	Revision note	Date	Signature
A	Höjd ökad 100 mm; Märkning	2008-12-01	JM
B	Vår 150; Nytt mått 170	2009-07-02	SC
C	Mittstolpe 30x30x3	2009-07-02	SC
D	Förstyvning	2009-09-29	SC
E	Aktre stöd ändrat. Art.nr uppdaterat.	2011-01-11	JM

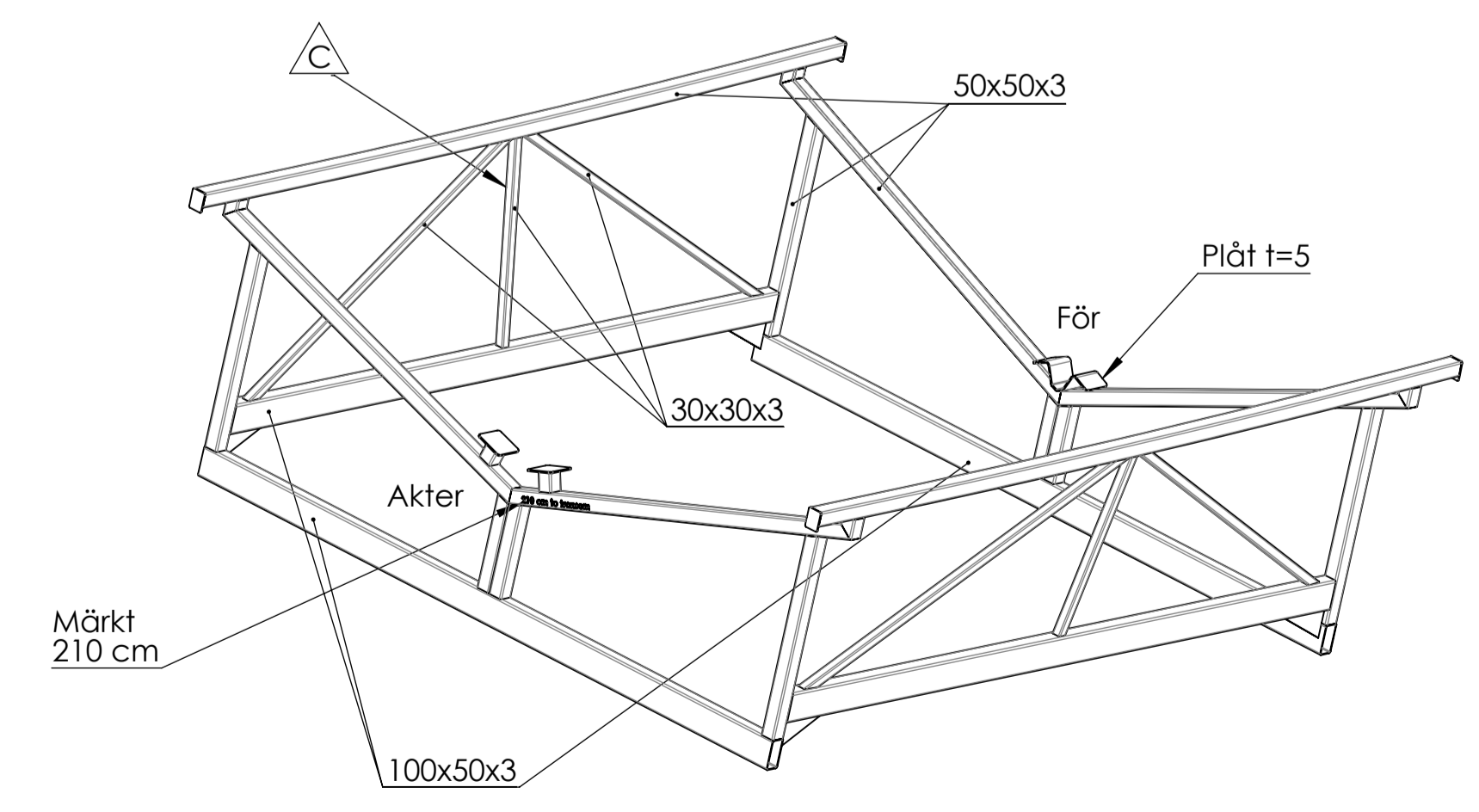

Copying of this document, and giving it to others and the use or communications of the contents thereof, are forbidden without our express authority. Offences are liable to prosecution and may be reported to the relevant authorities.

Utan vår uttryckliga tillstånd får denna handling inte utlämnas till obehörig eller kopieras. Ej heller får dess innehåll offentliggöra eller utnyttjas. All utövning av rättigheter är förbehållna för oss.

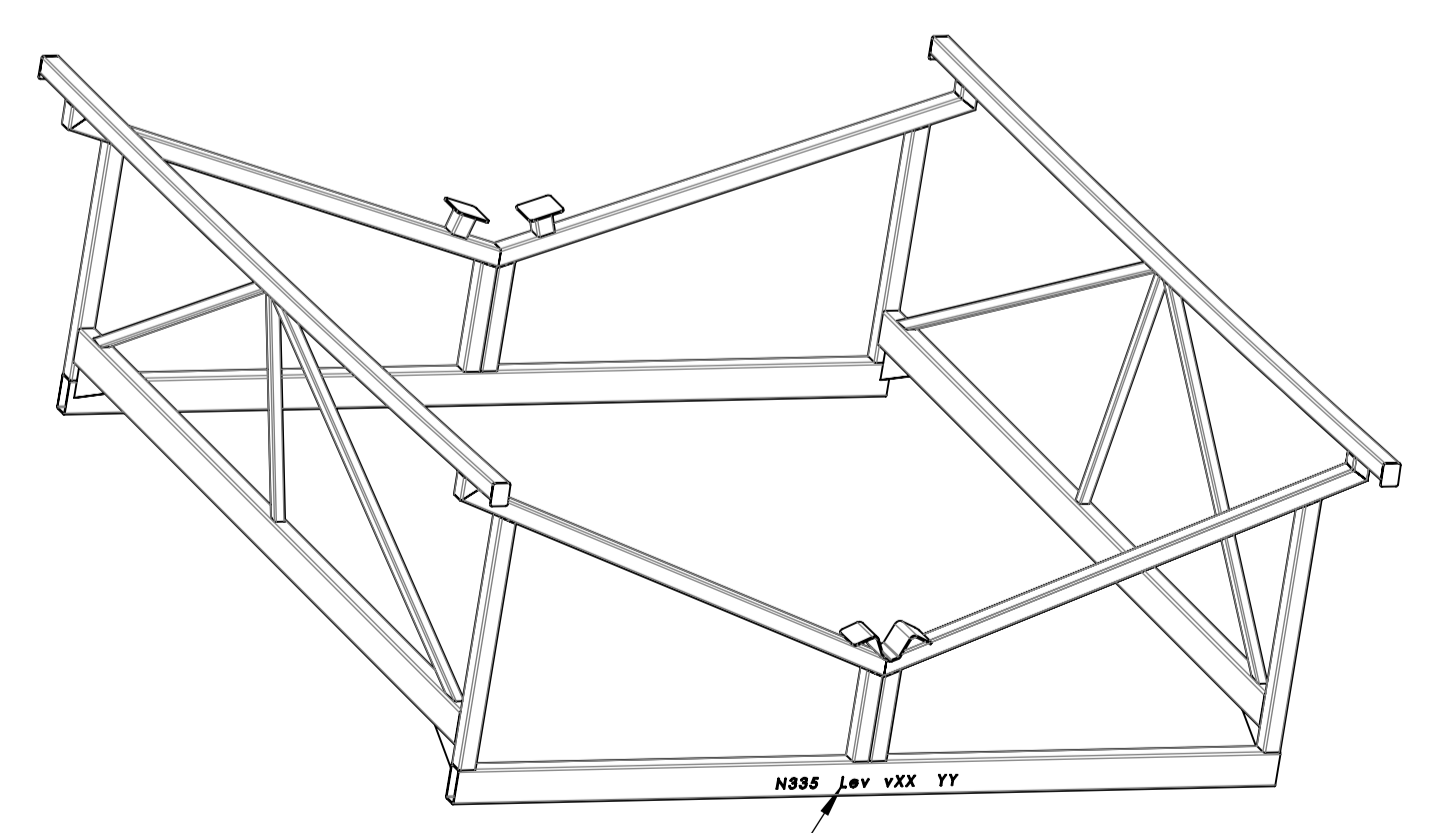
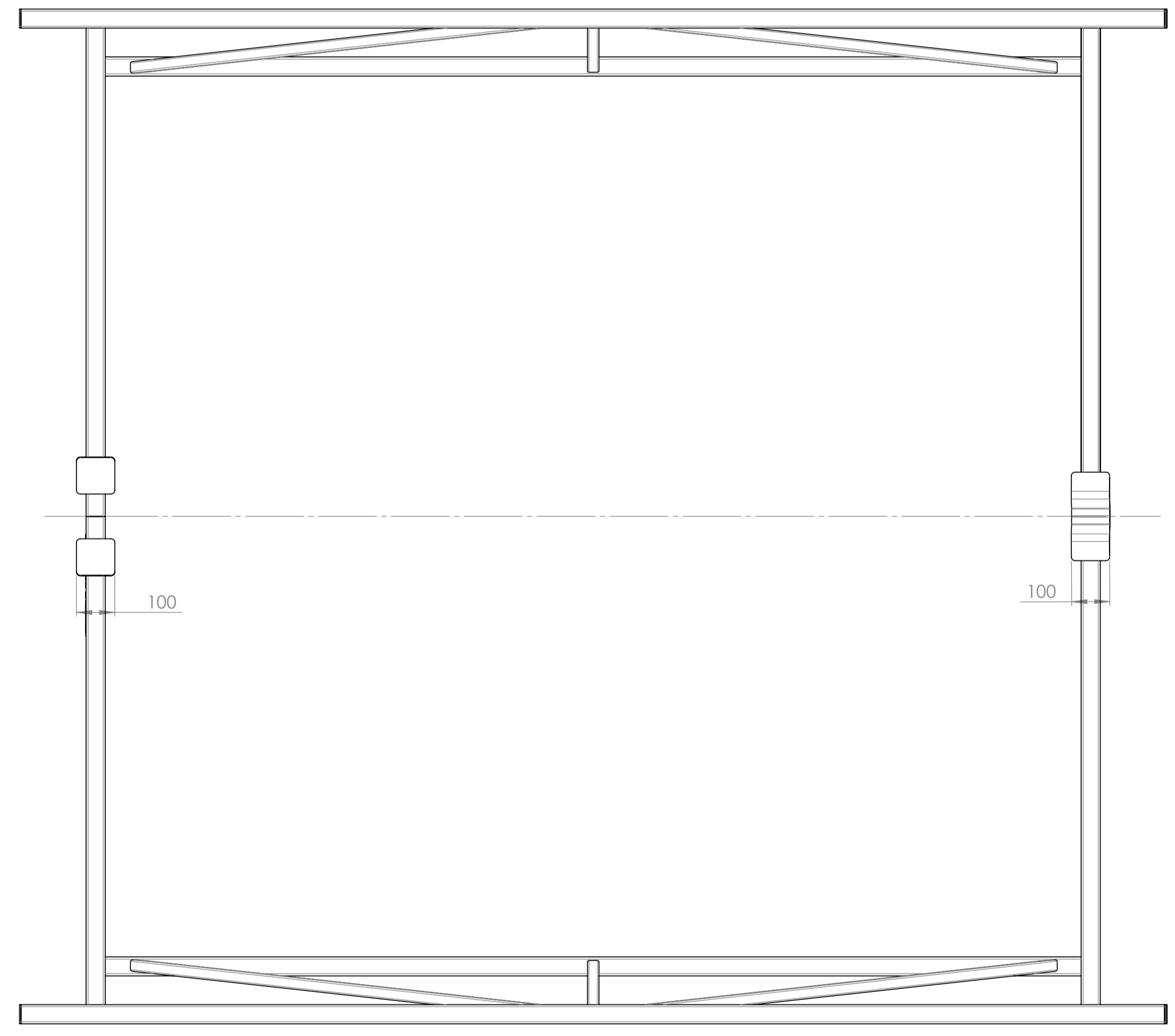
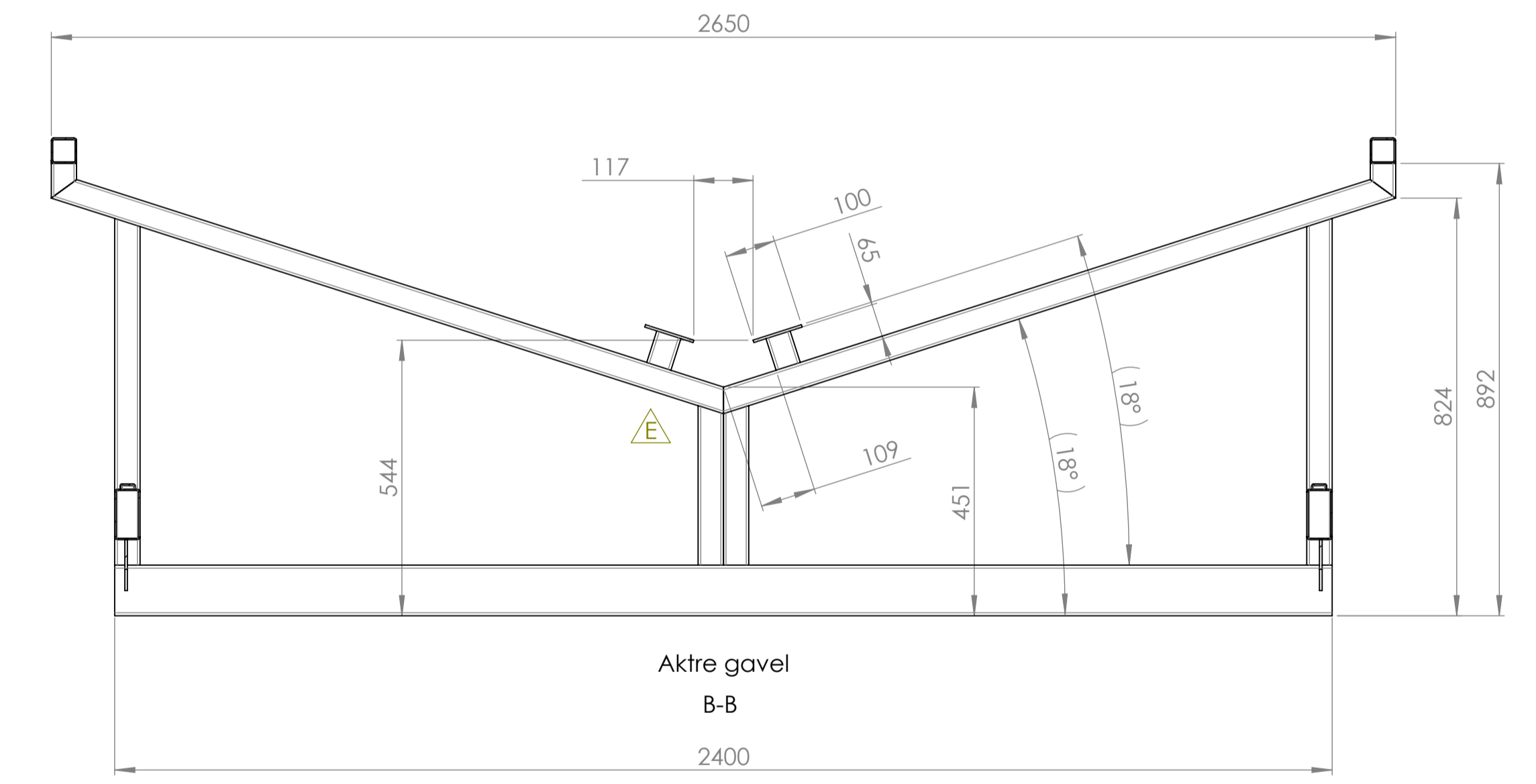
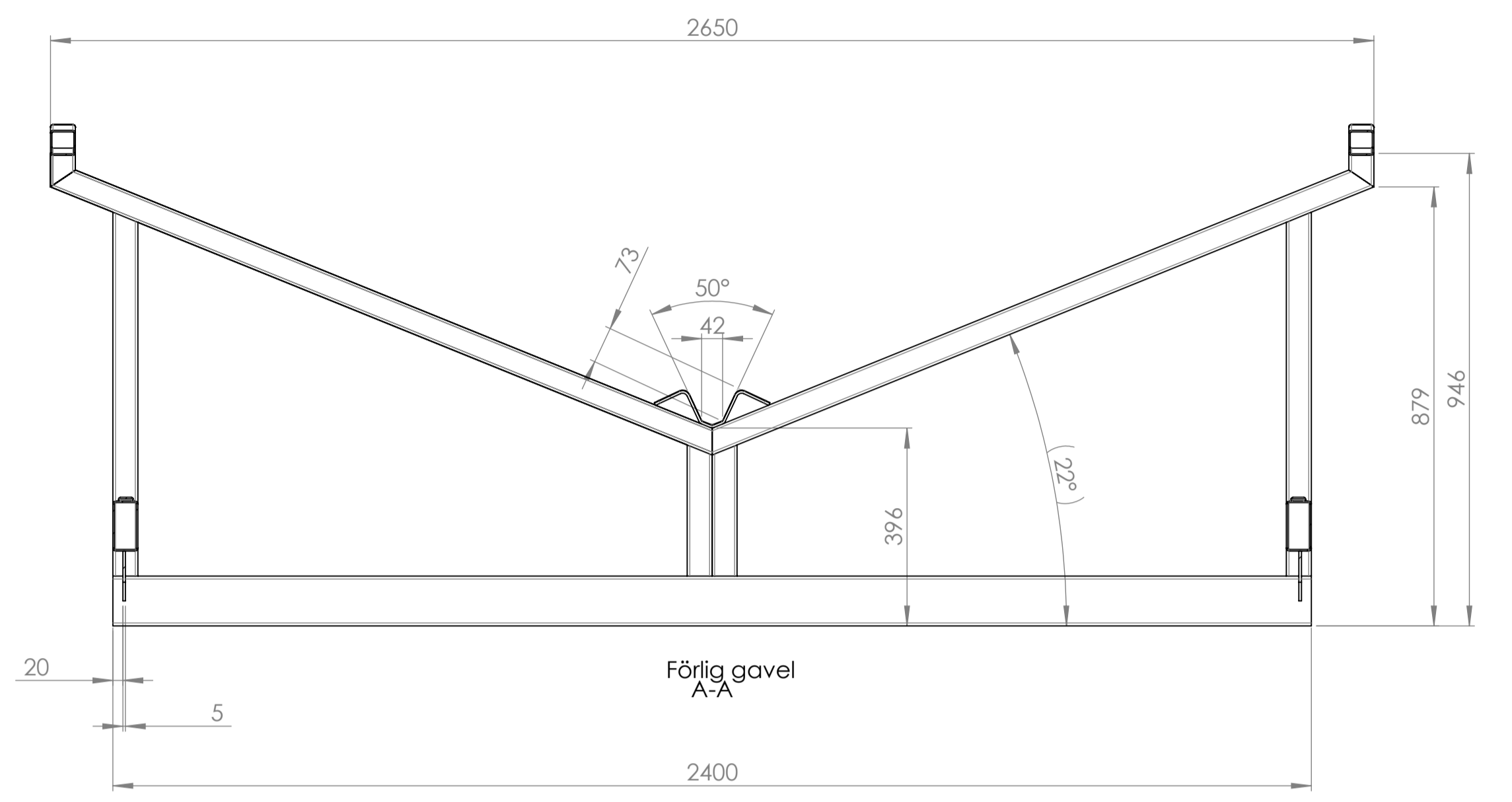
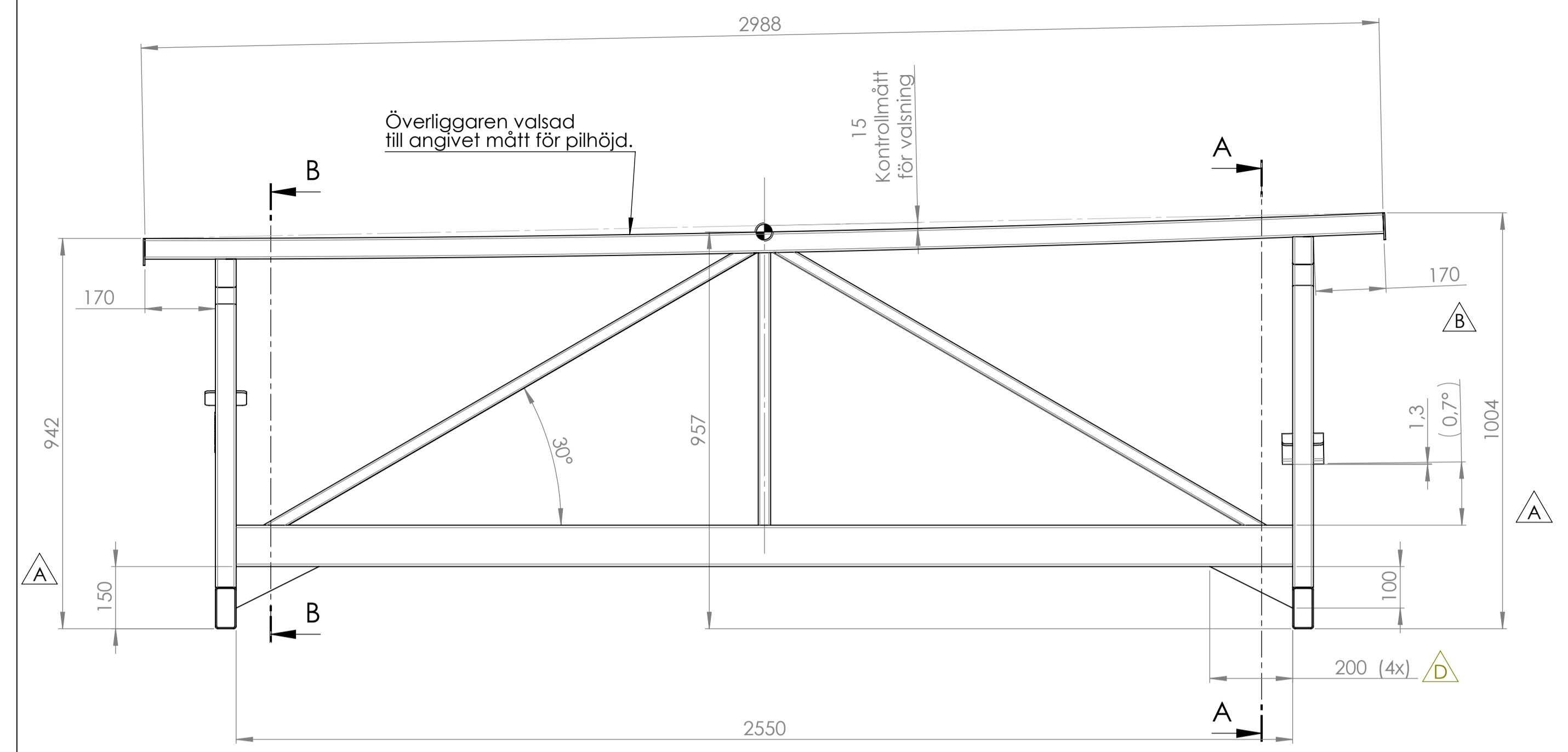
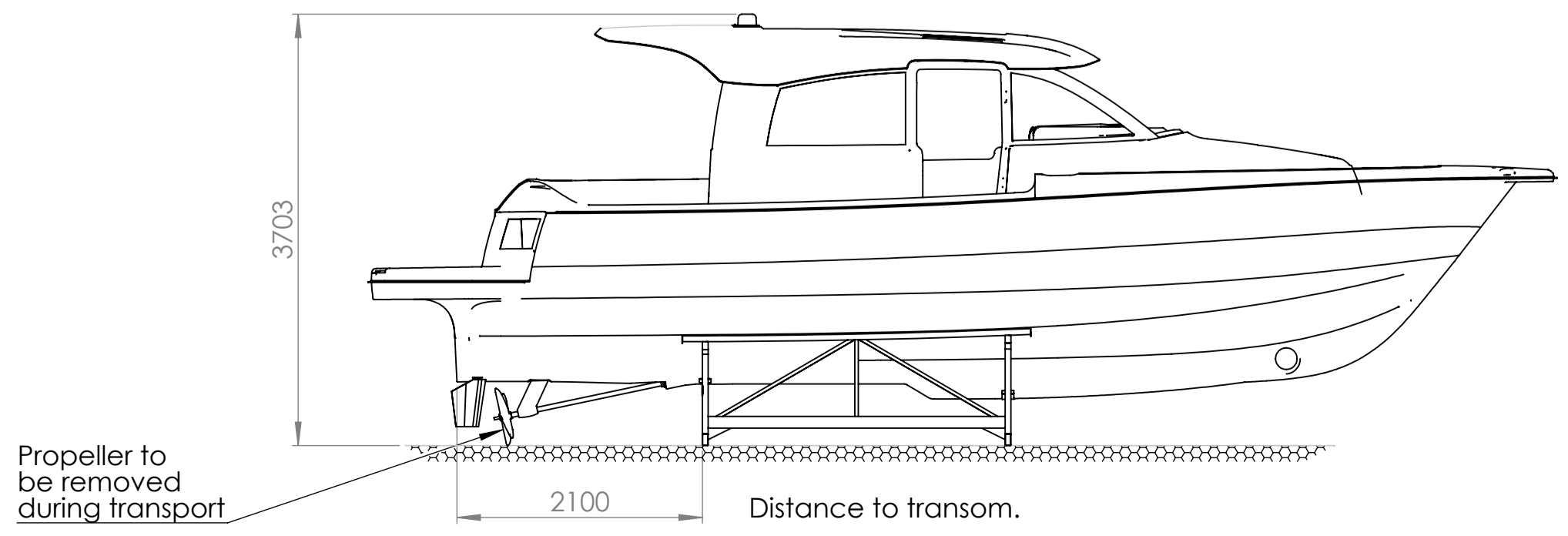

Ytbehandling: Rostskyddsmålad
 Skarpa kanter brutna.
 Beräknad vikt 151 kg

Konstr. av	Ritad av	Godk. av	Art.Nr	Datum	Skala	Blad
JM	JM	JM	3400207	2008-11-05	1:10	A1
			Benämning		NINBUS NC30 TRANSPORTVAGGA	
			Ritingsnr.		NC30-17263	
			Revision		Blad	
			E		1/1	



www.nimbus.se